



• 49175 WEST ROAD • P.O. BOX 930302 • WIXOM, MICHIGAN 48393 • PH. (248) 912-1970 • FAX (248) 912-1971 •
• Website: www.fluidautomation.com • E-mail: sales@fluidautomation.com •

Model 630 Servo Motor Powered Liquid Silicone Meter-Mix Unit

SPECIFICATIONS

General:

This machine is designed for mounting on or near an injection molding press for feeding A & B silicone, at a 1:1 ratio, to the feed throat of the press. Feed pumps supply material to one or many of these machines and an optional minor component such as color.

Operation:

When this single acting unit is designed for medium to large shots, the unit refills after the plasticizing cycle of the press finishes. For small shots, the unit can be programmed to refill after multiple shots to increase the efficiency of the system. Pressure transducers in the A & B meter cylinders must maintain a positive material

pressure while refilling to prevent the unit from drawing a vacuum. The unit must also reach a set packing pressure to assure both cylinders are full before closing inlet valves. The valves are independently controlled to compensate if different feed pressures exist or if the materials have different viscosities.

A linear encoder on the meter reports cylinder position to the PLC. This using this information combined with a set shot volume of a SN751 Color Injector, adjusting color percentages is as easy as entering the desired value on the operator interface panel.

A servo-electric cylinder extends two plungers to pump and retracts to refill. Pneumatic powered inlet and outlet valves for each material eliminates the need for a shut-off valve in the mixed material line. Feed throat pressure is controlled via closed loop between a pressure transducer at the barrel inlet and the servo meter.

A linear transducer on the meter gives absolute position and gives the needed pulses to allow color or 3rd stream addition programmable by percentage when used with the SN751 Color Injector.

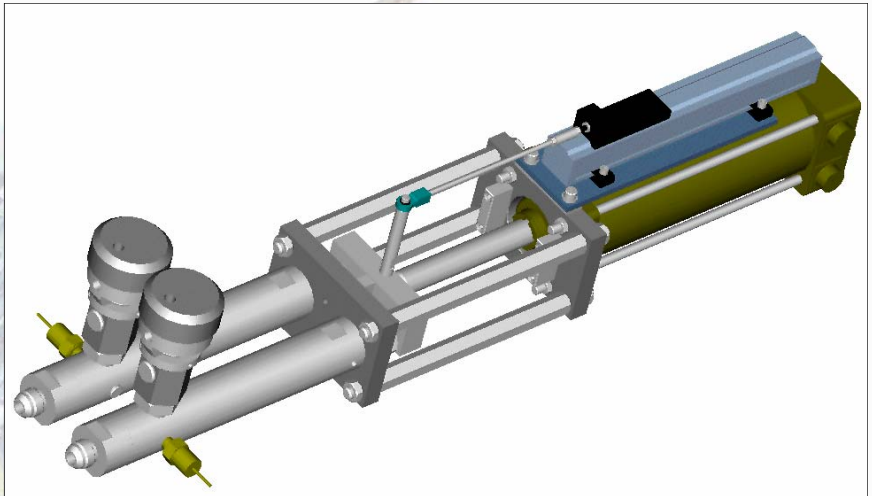

Not Shown: PLC Control Panel, Static Mixer, Manifold & Hoses

Specifications:

- 1:1 ratio
- 2000 psi maximum feed pressure at barrel inlet
- 75cc per cylinder, 150cc maximum shot size.
- Programmable feed pressure at barrel inlet
- Refill rate tied to A & B meter transducers assure never drawing vacuum during refill
- Maximum refill time of 3 seconds with 2000 psi feed pump pressure
- Third stream program included as standard
- Includes: PLC Control Panel, Hoses, Mixer & Manifold

Advantages:

- Single acting design with closed loop servo control will give absolutely repeatable pressure at barrel inlet. This design removes any possibility of feed pressure variations affecting injection press shot size.
- Fewer valves than other designs, lowering cost and simplifying maintenance.
- Reduced number of components in mixed material stream results in less cleaning and maintenance costs. (no fluid pressure regulator or interface shutoff valve is required)
- Highly accurate A, B and third stream ratios.

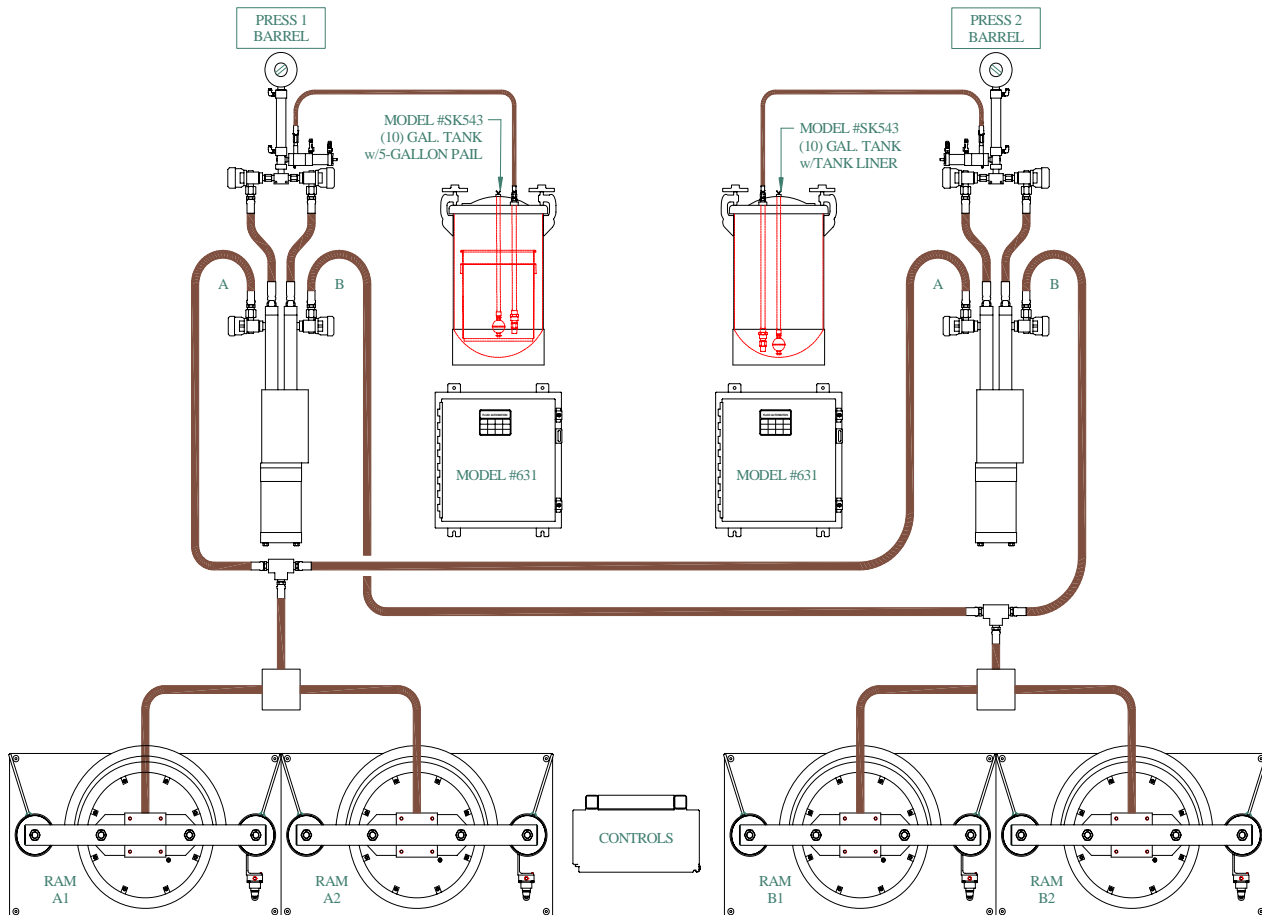

SR657-4 AUTOMATIC CHANGEOVER FEED SYSTEM

Description

This system drawing shows an automatic changeover feed station feeding two metering units on two injection molding machines. This reduces costly downtime that occurs while production stops to change material drum on a conventional “Direct from the drum” style machine. This system is also scalable starting with one metering unit and the feed system and adding metering stations as production volumes increase. This is a considerable cost saving when coupled to three even four metering units compared to individual meter-mix units for each injection molding machines. As shown above, separate color injectors supply pigment to each metering eliminating the need to feed the same color to both presses. Color percentages are entered via the operator interface panel instead of moving a mechanical slave device. Pigment can be fed from a variety of different feed systems. With the mindset of reducing loss of production due to down time, we recommend a 10-gallon pressure tank as shown above. These tanks have low level sensors that are monitored by the 630 controller and signal when pigment need to be added. If pigment is supplied in a 5-gallon pail, you can simply stir the contents and then place the pail into the pressure tank. The tanks are also fitted with disposable liners. The pigment can be poured directly into the 10-gallon tank increasing the total volume of pigment between refills.

Recommendations

- Used in long running applications using the same A & B compounds due to increased maintenance time for cleaning.
- Scalable up to 5 units depending on the combined shot size from each injection molding machine.