

FLUID Automation, Inc

• 49175 WEST ROAD • P.O. BOX 930302 • WIXOM, MICHIGAN 48393 • PH. (248) 912-1970 • FAX (248) 912-1971 •
• Website: www.fluidautomation.com • E-mail: sales@fluidautomation.com •

MODEL 201 & 201H 10:1 RATIO METER-MIX MACHINES

201 FEATURES

- 8" AIR CYLINDER
- LOW BASE LEVEL & HIGH PRESSURE SWITCHES
- ADJUSTABLE CATALYST RATIO.
- GRAVITY FED CATALYST TANK
- DIRECT FROM DRUM RESIN FEED.
- 1" O.D. STATIC MIXER
- SOLVENT FLUSH SYSTEM
- 1/2" BALL VALVE OUTLET

201H FEATURES

- 8" AIR CYLINDER
- LOW LEVEL & HIGH PRESSURE INDICATORS
- ADJUSTABLE CATALYST RATIO.
- GRAVITY FED CATALYST TANK
- DIRECT FROM DRUM RESIN FEED.
- SG225 GUN WITH DISPOSABLE STATIC MIXERS.

SPECIAL 201 OPTIONS

- ADDITIONAL THIRD STREAM METERING FOR OILS OR PIGMENT
- CATALYST AGITATOR
- PIVOT ARM FOR MIXER ASSEMBLY



MACHINE SPECIFICATIONS

VISCOSITY RANGE:	20,000 TO 200,000 CENTIPOISE (CPS)
201 FLOW RATE (WITH 1" O.D. MIXER):	UP TO 8 lb/min OF 100,000 CPS MIX UP TO 15 lb/min OF 20,000 CPS MIX
201H FLOW RATE (WITH SG225 HANDGUN):	2 TO 4 lb/min
MAXIMUM OUTPUT PRESSURE:	3,500 PSI
RATIO RANGE:	7:1 TO 15:1 BY VOLUME
AIR REQUIREMENT:	10 CFM @ 100 psi
POWER REQUIREMENT:	120 VAC / 50-60 CYCLE / SINGLE PHASE
ELECTRICAL CURRENT REQUIREMENT:	3 AMPS.
WEIGHT:	700 POUNDS
HEIGHT REQUIREMENT (EXTENDED):	107 INCHES (272 CENTIMETERS)
HEIGHT REQUIREMENT (RETRACTED):	70 INCHES (178 CENTIMETERS)

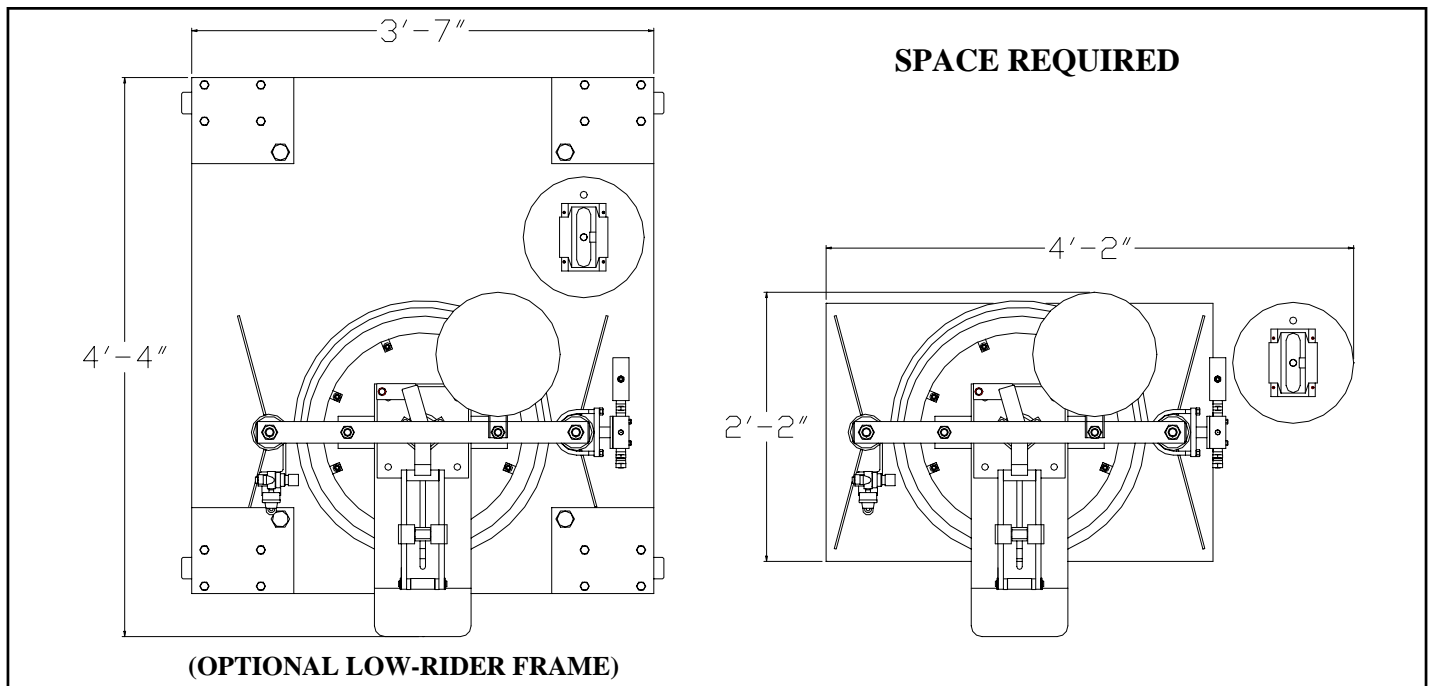

OPTIONAL ACCESSORIES

- LR LOW RIDER FRAME AND CASTORS (REQUIRES DIFFERENT BASE PLATE)
- 3P THIRD STREAM METERING OPTION FOR SILICONE OIL OR PIGMENT
- AG CATALYST FEED TANK AGITATOR
- SA940 PIVOTING SWING ARM FOR MOUNTED STATIC MIXER
- SG225 HAND GUN ASSEMBLY WITH DISPOSABLE STATIC MIXERS
- B240 INDUSTRIAL METERING PUMP (USED WITH HAND GUN ASSEMBLY ONLY)